



EVOLUTION of ATNF

RECEIVER INSTRUMENTATION

FOR RADIO ASTRONOMY SINCE 1960



# Introduction

In the 50 odd years since 1960, radio astronomy receiver instrumentation has undergone significant change.

The quest for low noise, wideband, stable reception of the incredibly weak signals from the cosmos has seen a gradual evolution of the technology from vacuum tube RF and IF amplifiers, crystal mixer converters, parametric LNA's, bipolar transistor amplifiers, maser LNA's (operating at liquid He temps), MESFET transistor LNA's and finally the GaAs and InP HEMT based LNA's of the present day.

# Murraybank H-line (1958)



7 metre alt-az mounted  
paraboloid.

Prime focus front-end.  
Mixer if preamplifier  
 $B = 2 \text{ Mhz}$   $T_s = 800 \text{ K}$

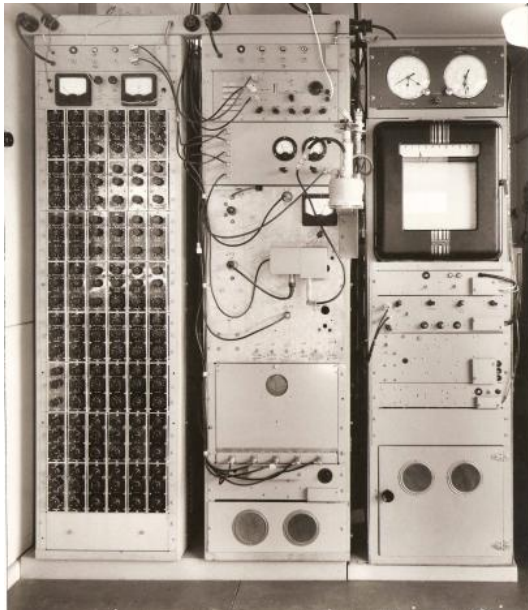
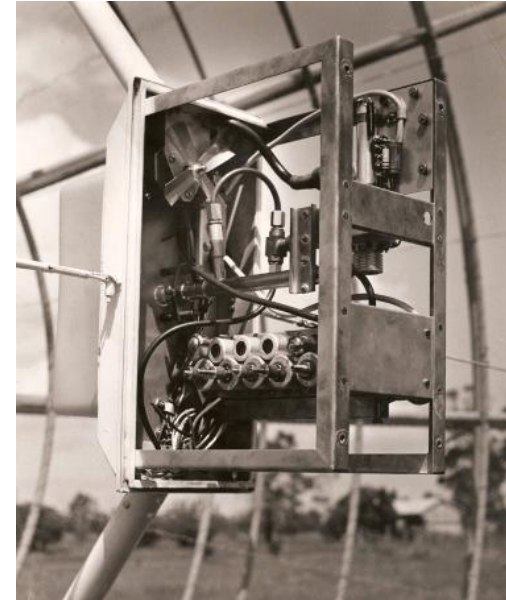

Backend synch det,  
LO multiplier and  
recorder racks.

48 channel filter bank  
 $B = 33 \text{ khz}$ ,  $V_{res} = 7 \text{ km/s}$

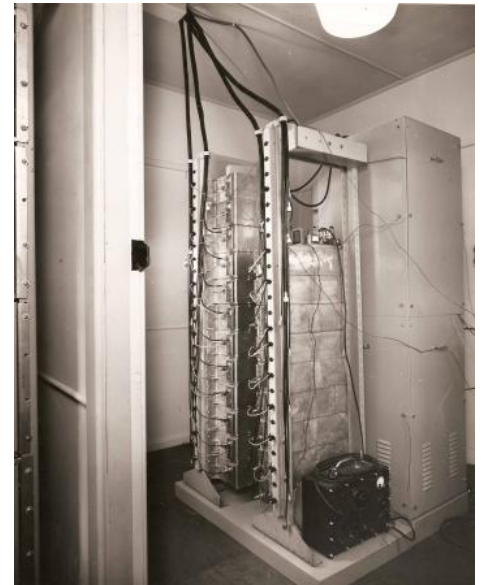

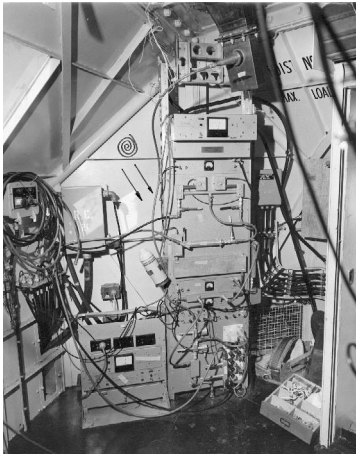

## THE EARLY PARKES RECEIVERS (1962 – 1965)

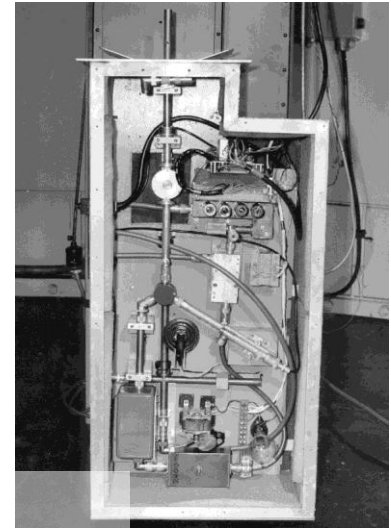

- Acceptance Testing
  - 75, 20 & 10 cm Crystal Mixers
- Mk I H-line Receiver
  - Ex-Murraybank Multichannel
- 20 cm Cooled Paramp Receiver
- 11 cm Ambient Paramp Receiver
- Extra Galactic H-line Paramp System

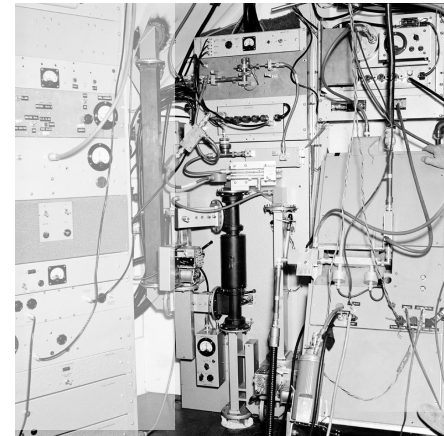

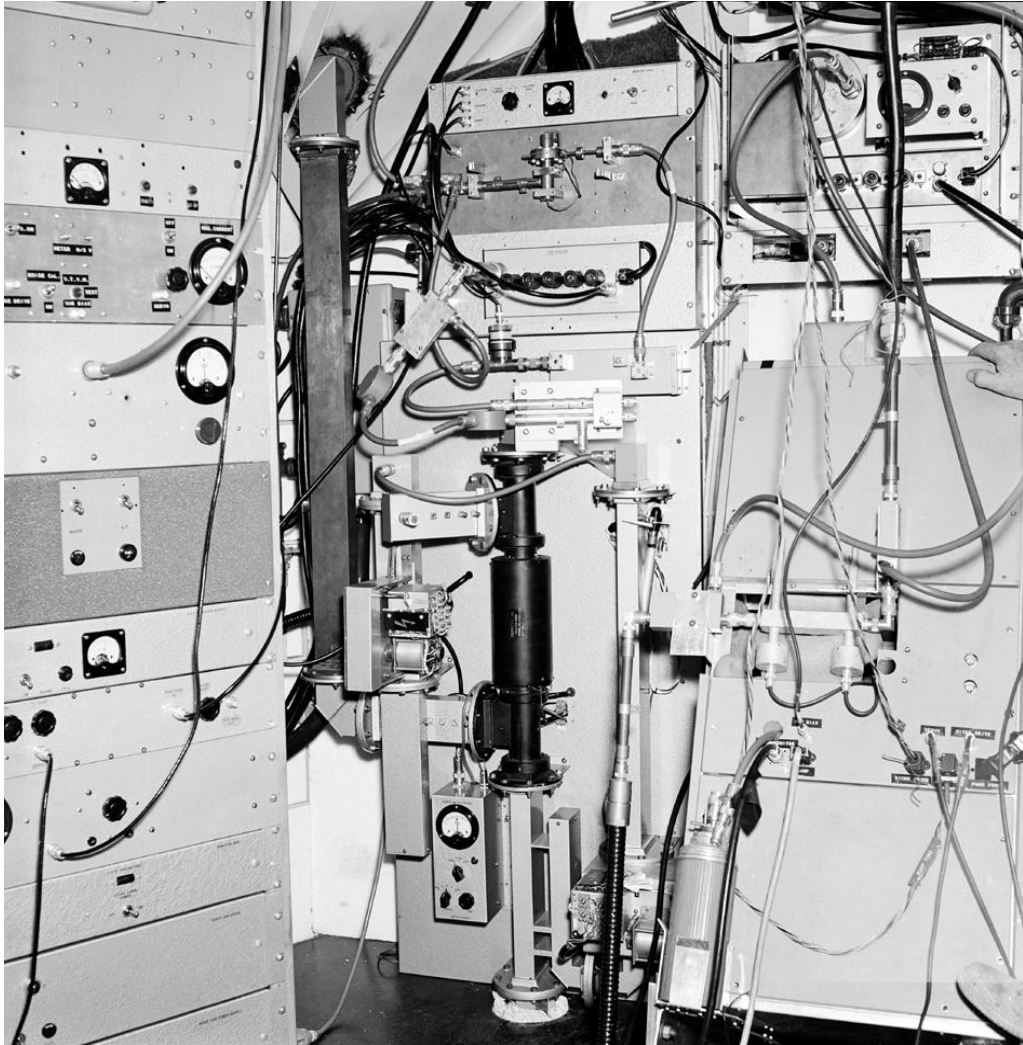

20 Cm degenerate Paramp (cooled).  
 $T_s = 110\text{K}$   $B = 20\text{ Mhz}$ .  
11cm Room Temp Paramp.  
 $T_s = 180\text{K}$   $B = 100\text{ Mhz}$

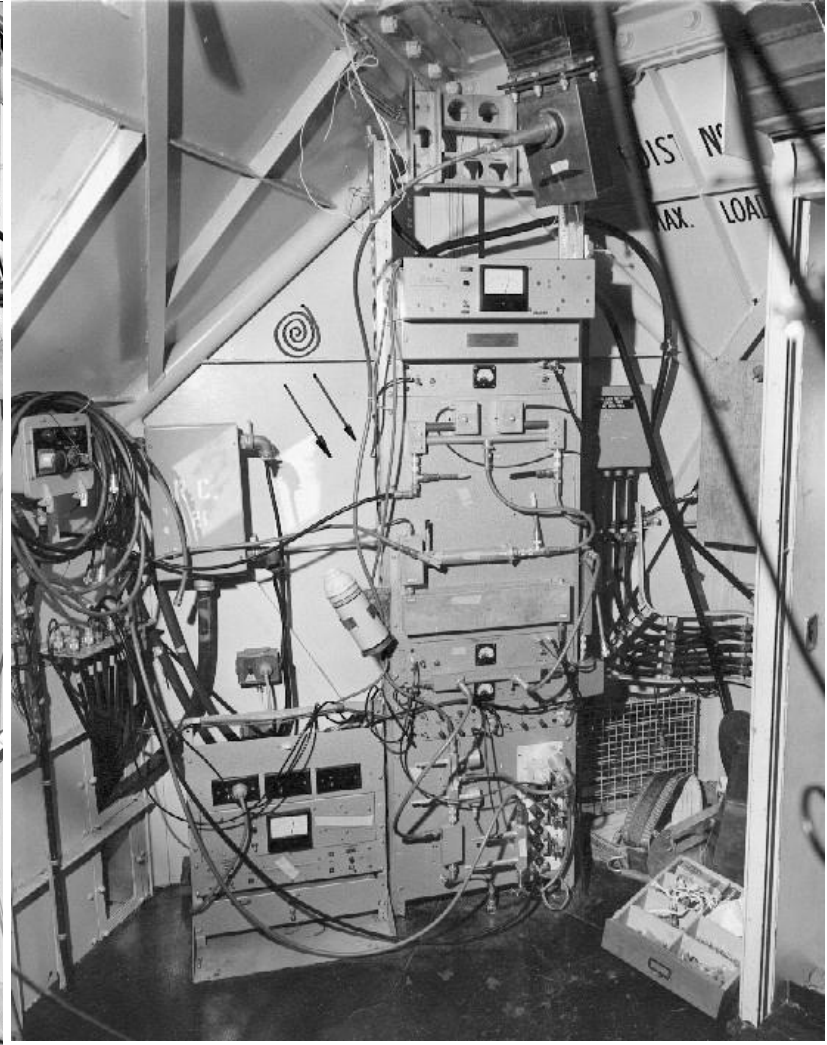

Acceptance Receivers  
75 Cm Crystal Mixer and IF Amp.  
20 Cm Crystal Mixer and IF Amp

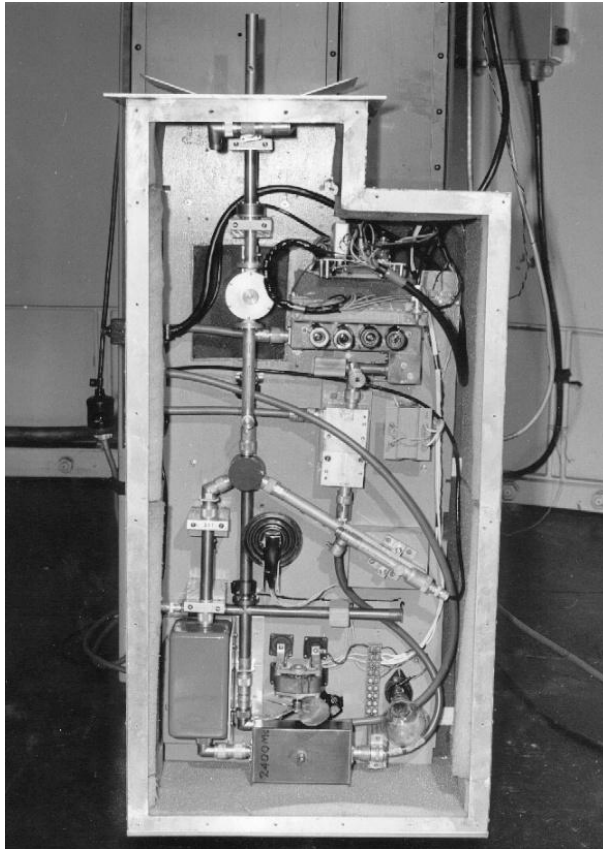

The First Hydrogen  
Line Receivers



Extra Galactic H-Line  
Upconverter into a 2.8 Ghz  
Degenerate parametric  
Amplifier.  
 $T_s = 160K$   $B = 100$  Mhz

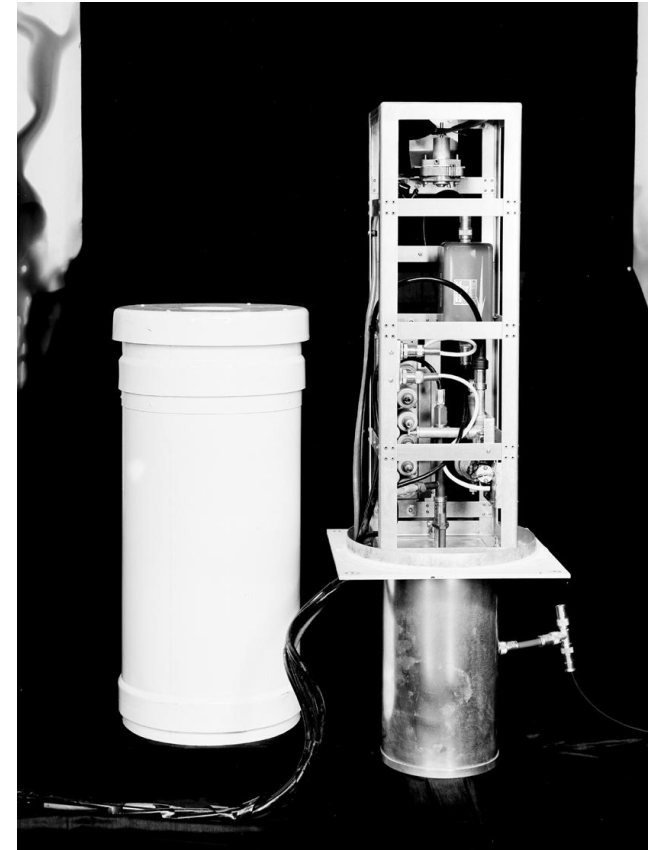

Multi-channel H-line Front  
End.  
Crystal Mixer into an  
IF amplifier.  
 $T_s = 700K$   $B = 2$  Mhz

# 20 Cm Cooled Degenerate Parametric Amplifier Receiver System.

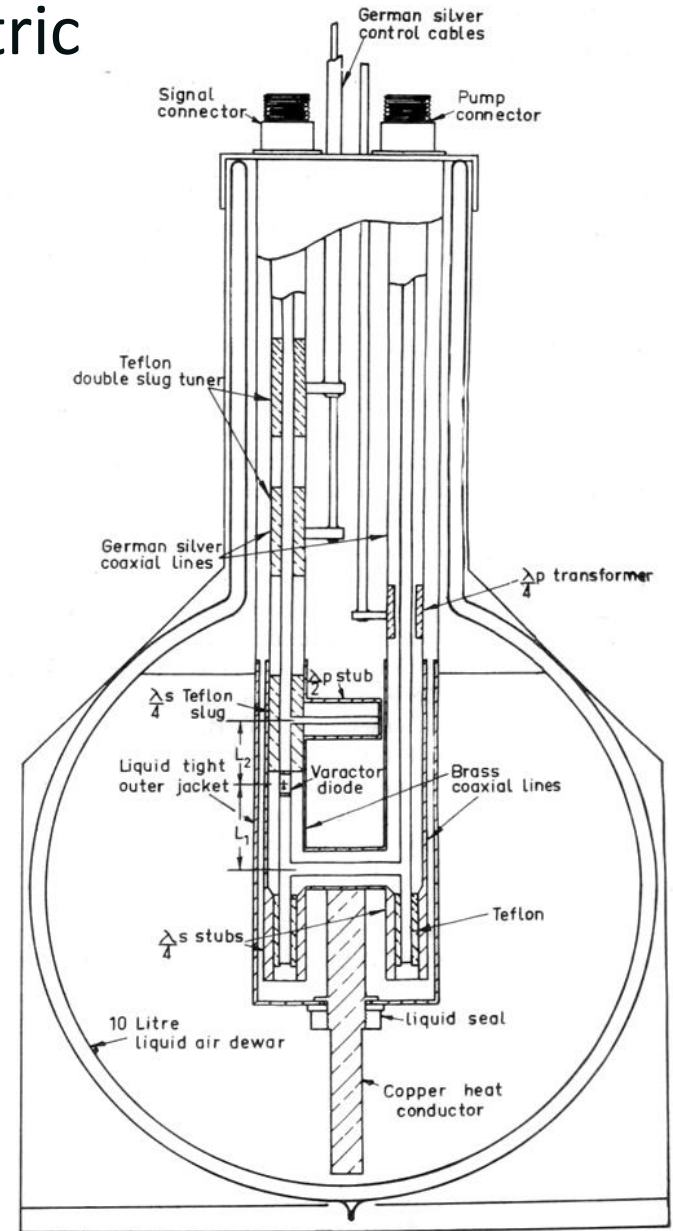
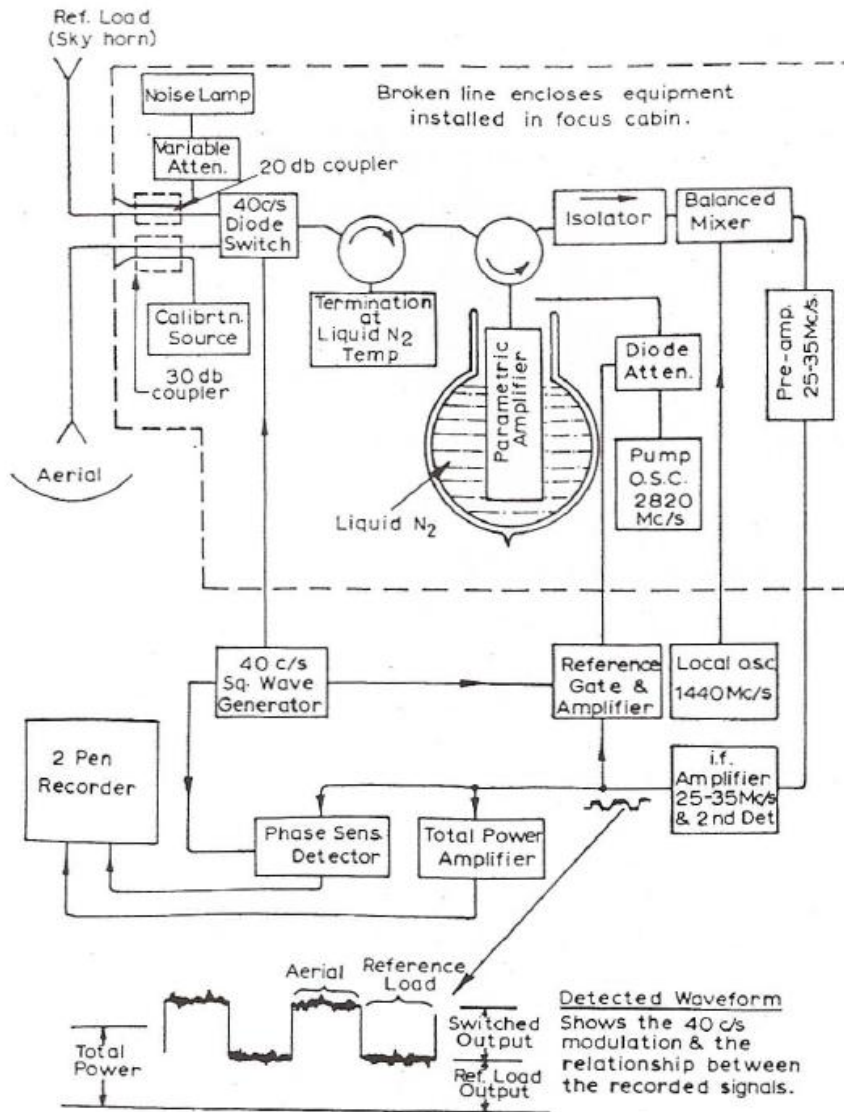

Figure 3.—Section through dewar and parametric amplifier showing the general construction.

# PARAMETRIC AMPLIFIER SYSTEMS (1960-1975 )

## Ambient Temperature Systems

21 cm H-line ( $T_s = 200\text{K}$ ,  $B = 50\text{MHz}$ )

18 cm OH-line ( $T_s = 150\text{K}$ ,  $B = 30\text{MHz}$ )

( 1612, 1665, 1667, 1720

11 cm Correlation Receiver (1967-1979)

(Dual Channel  $T_s = 80\text{K}$ ,  $B = 200\text{MHz}$ )

21 cm H-line uMega paramp.

(  $T_s = 90\text{K}$ ,  $B = 50\text{MHz}$  )

18 cm OH-line dual channel, IF polarimeter,  
uMega Paramps tuneable 1612 to 1720 Mhz

(  $T_s = 90\text{K}$ ,  $B = 50\text{MHz}$  )

5 cm Excited OH-line Receiver.

Tuneable 6030 to 6035 Mhz

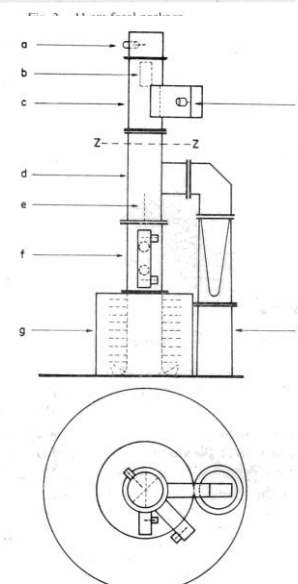
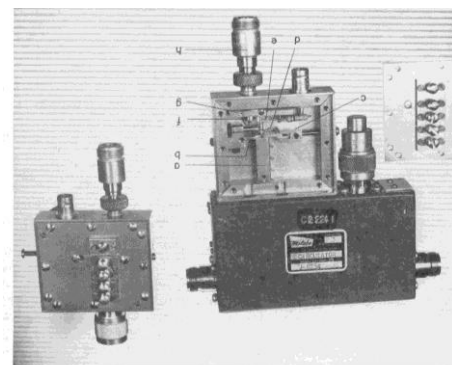
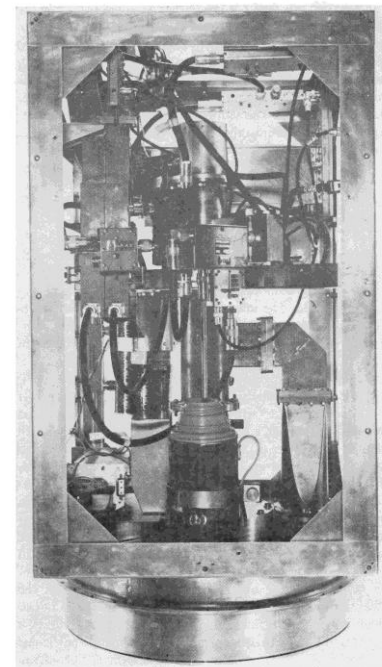



# PARAMETRIC AMPLIFIER SYSTEMS (1970-80)

## Cryogenically Cooled (20K) Amplifier Systems.

NRAO 6 Cm Receiver (  $T_s=100K$ ,  $B=150$  Mhz)

6 Cm RP/AIL Receiver (  $T_s=50K$ ,  $B=500$  Mhz)

In service from 1970 till 1984. Was repackaged in 1975 to improve noise performance. Single channel.

3.4 Cm Tony Kerr Receiver (  $T_s=100K$ ,  $B=50$  Mhz)

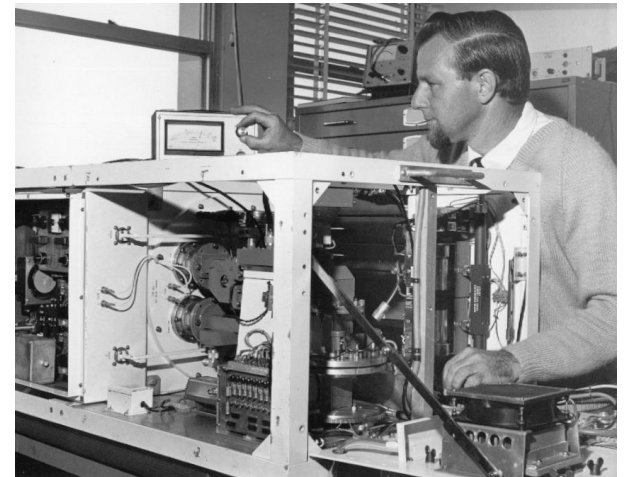
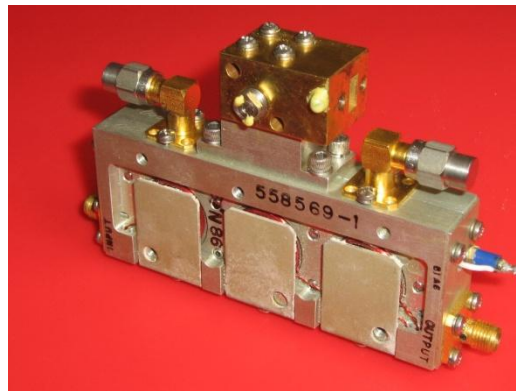

# THE EARLY SPECTROMETERS (1960-1980)

- Mk I Multichannel Filterbank
  - 48 Channels  $B = 33\text{Khz}$
- Mk II Multichannel Filterbank
  - 64 Channels  $B = 1, 10 \text{ \& } 100 \text{ Khz}$
  - 33 Khz later
- Mk I Digital Correlator
  - 1024 Channels – 1 bit
  - 512 Channels – 2 bit
  - $B = 10\text{Mhz}$
- Acousto-Optic Spectrograph
  - $B = 100\text{Mhz}$

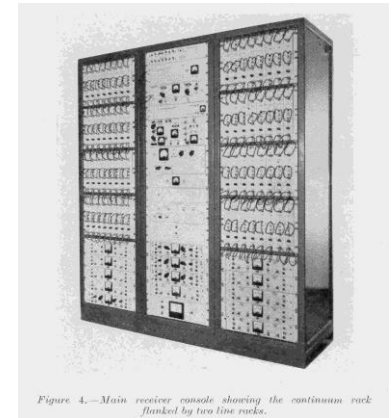
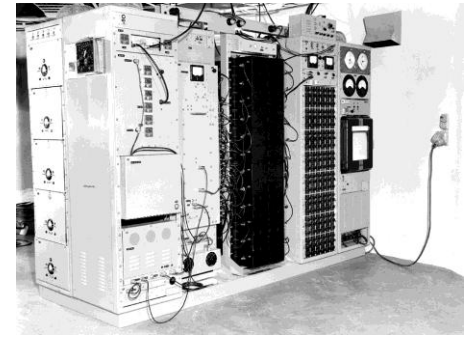
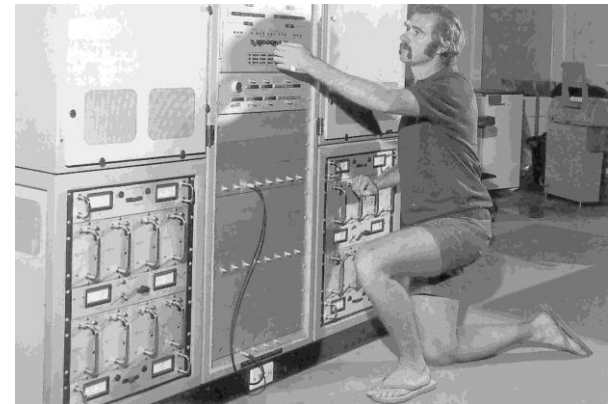
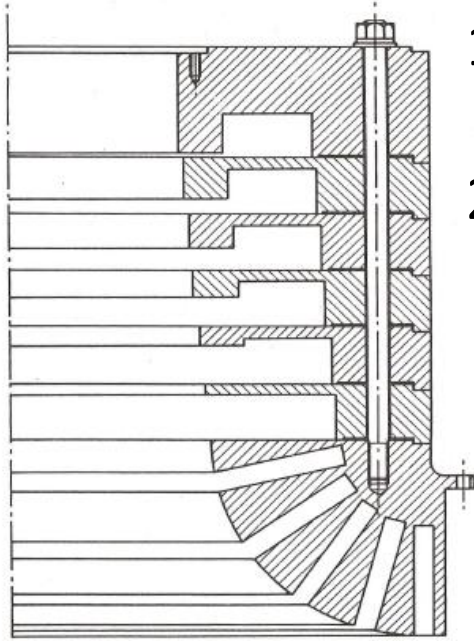

Figure 4.—Main receiver console showing the continuum rack flanked by two line racks.



# HYBRID MODE FEED HORNS

Early receiver feeds were dipole arrays, rectangular and circular waveguide or tapered choke ring apertures. Research by the Radiophysics Antenna Group resulted in the development of two types of corrugated feed horns— 1HE and 2HE



1HE horns – Wide band, circular beam, smaller size.

2HE Horns – Narrow band, more efficient, large.



Corrugated wideband  
1HE horn section.

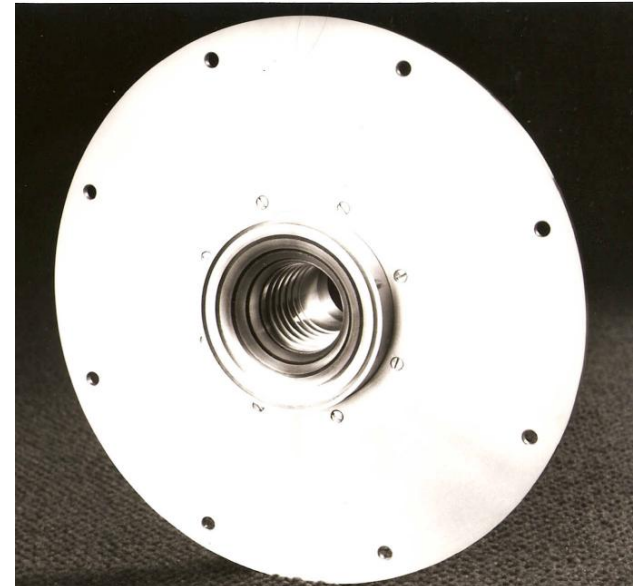

# THE MOVE TO SHORTER WAVELENGTHS (1975-1985)

To take advantage of the reflector surface improvements, new receivers were developed for astronomically interesting bands at long mm wavelengths.

1.3 Cm Mixers at Ambient and LN2 temperatures. The cooled mixer utilised the 6 Cm cooled paramp as an IF amplifier. A 7mm and 3mm cryogenic front end for the Epping 4m telescope was used to evaluate the 17m inner mm surface.

22 Ghz (1.3 Cm) Maser



$T_s=80K$   
 $B=250\text{ Mhz}$

42 Ghz (0.7 Cm) Maser



$T_s=110K$   
 $B=100\text{ Mhz}$

# CRYOGENIC FIELD EFFECT TRANSISTOR AMPLIFIERS

- Multifrequency Front End.
  - AT Prototype Amplifiers (using GaAs MESFETS)
    - 20, 13, 6 & 3cm Amplifiers all in one Dewar
    - $T_s = 40, 50, 60, 70K$
    - $B > 500Mhz$  (Better telescope scheduling)

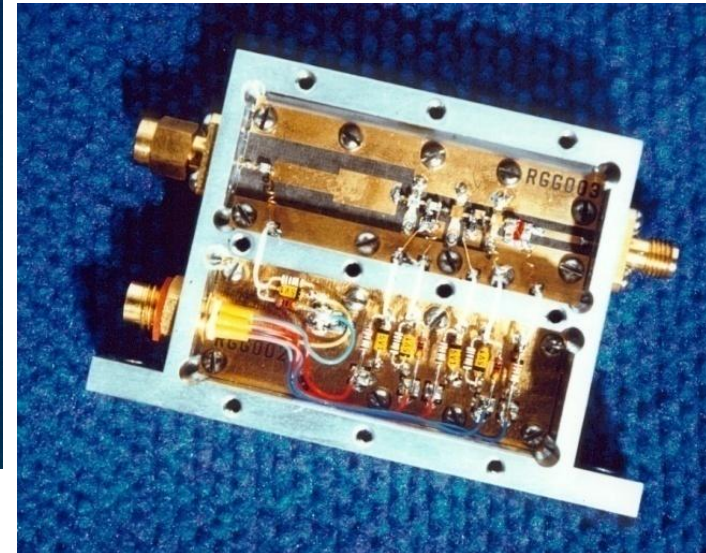
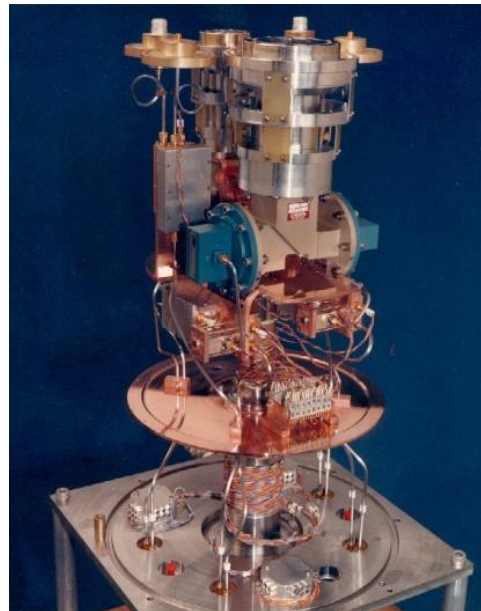
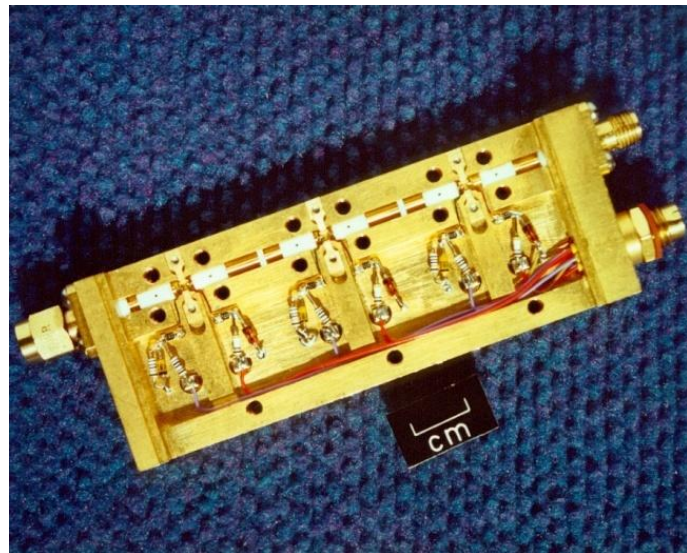

# WIDEBAND H-OH RECEIVER (1993).

1.2 to 1.8 GHz frequency coverage, cooled GaAs HEMT amplifiers and a cooled orthomode transition.

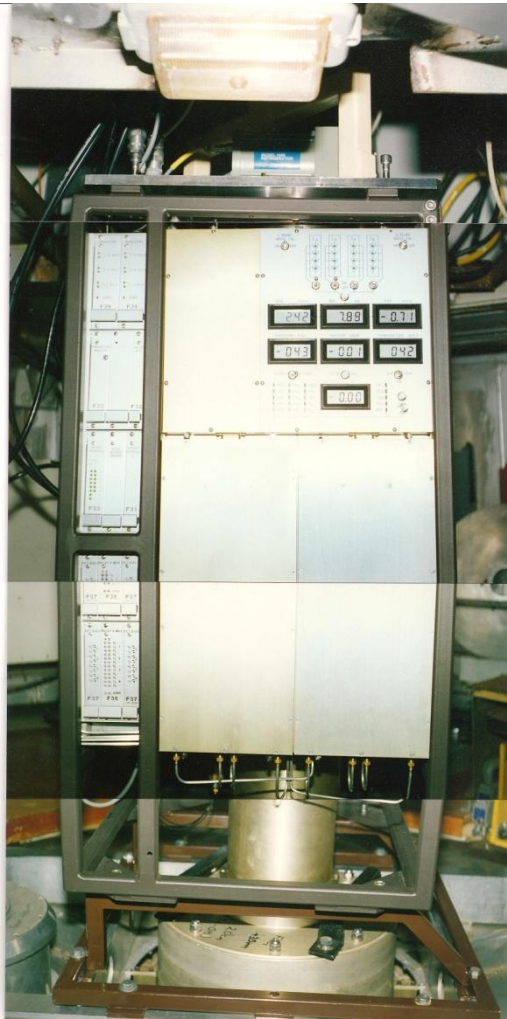

HOH Receiver Zenith System Temperature on Parkes 64 m Telescope

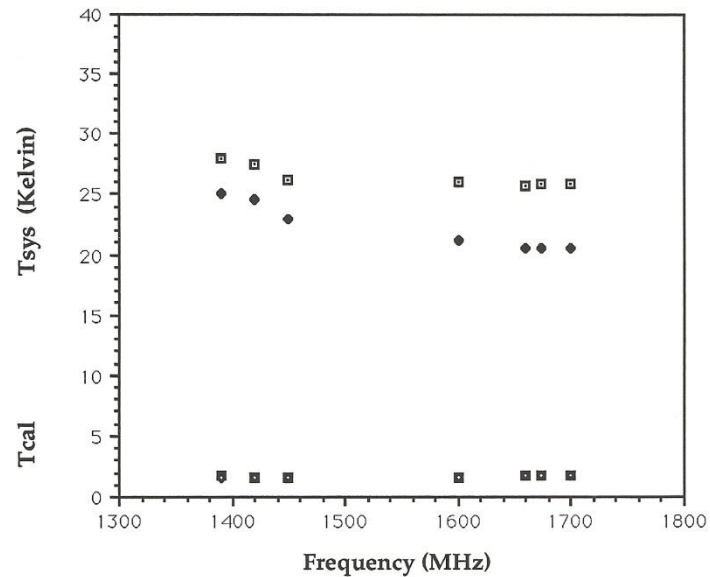



# 21 CM H-LINE MULTIBEAM RECEIVER 1996

## System Performance

- *RF Performance*

- Operating frequency 1230 → 1530 MHz
- Overall front end gain: 68 db  
(40db - cryogenic)  
(28db - ambient)
- Receiver noise temperature: 6 Kelvin  
(average of 26 receivers)

- *Telescope Performance*

- System noise temperature: 24 Kelvin  
(average of 26 receivers)
- Telescope - Feed Efficiency

	<u>Theor.</u>	<u>Measured</u>
Beam 1	69%	63%
Beam 2	-	59%
Beam 3	60%	50%

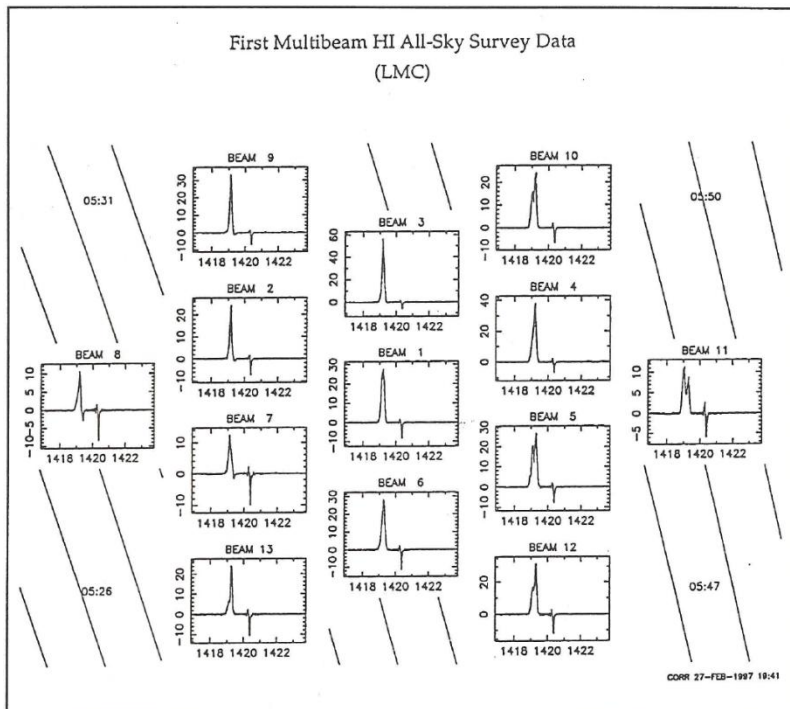

# AUSTRALIA TELESCOPE COMPACT ARRAY 1990



- 22 metre Cassegrain fed shaped optics.
- Initial freq bands 20/13 and 6/3.5 cms
- Cryo MESFET LNA's used for all bands
- Phase stable LO generated from references distributed by buried cable
- Conversion to 64/128 Mhz IF bands.
- IF bands digitised. Data via f/optic link to central site.
- Ts: 20 cm-33K, 13 Cm-36K, 6Cm-50K, 3.5-65K.

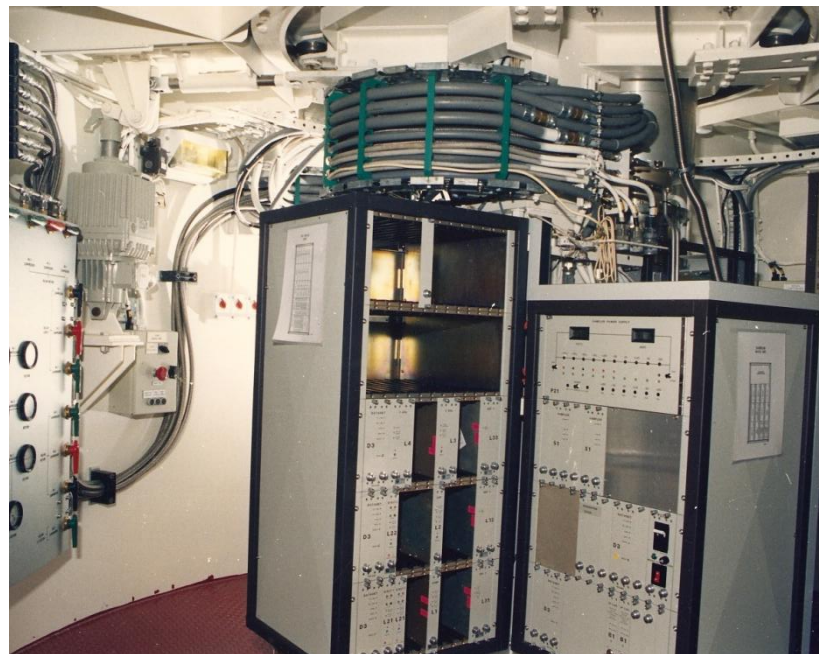
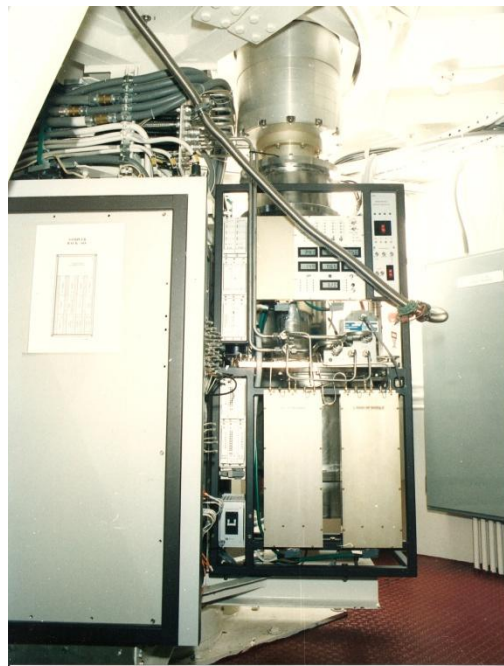



# MOPRA mmWAVE FACILITY



- 22 metre Cass fed wheel on track for better surface stability.
- Dual poln SIS Mixer-IF amplifier receiver. (Supercond-Ins-Supercond)
- Operates at 4.2 Kelvin (liquid He)
- Operating band: 90 Ghz to 115 Ghz (3mm band). IF at 1.5 Ghz, B= 500 Mhz.
- Ts on Sky approx 140 Kelvin.

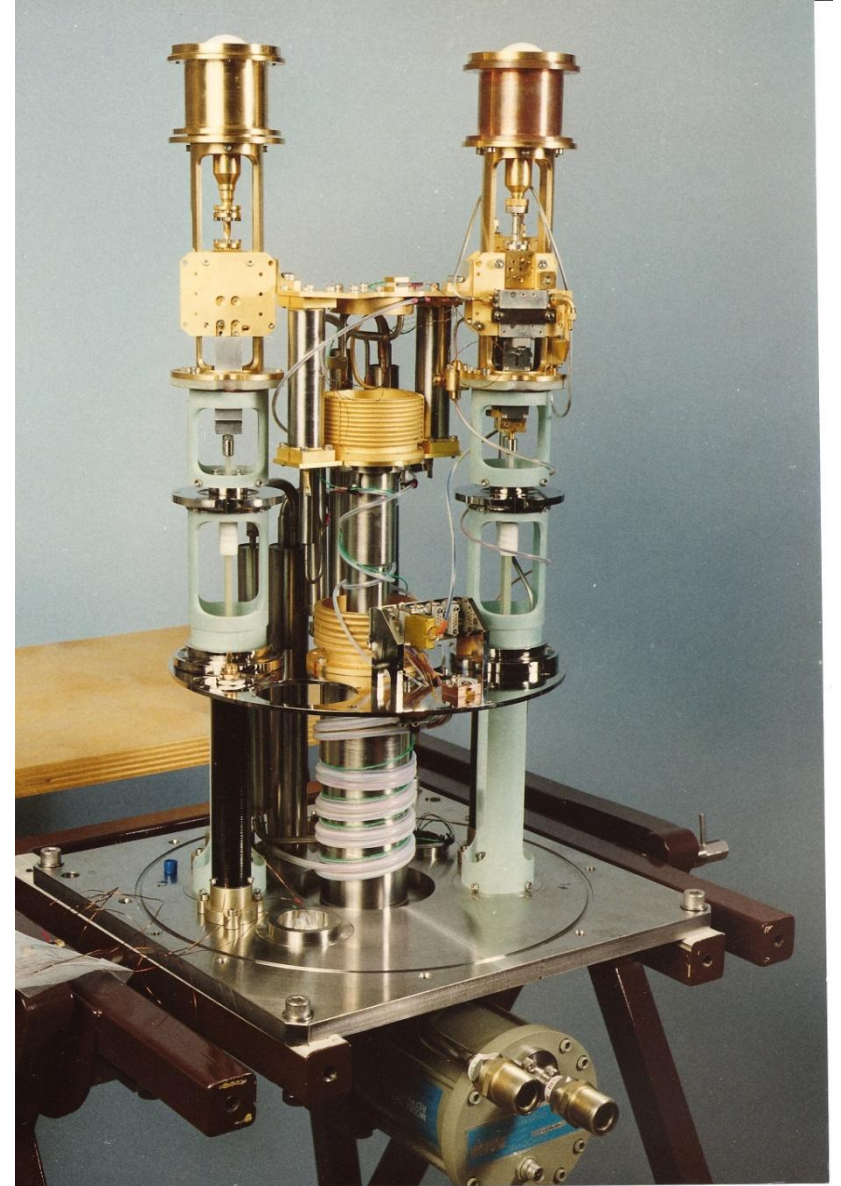

# COMPACT ARRAY mmWAVE UPGRADE (MNRF) 1996

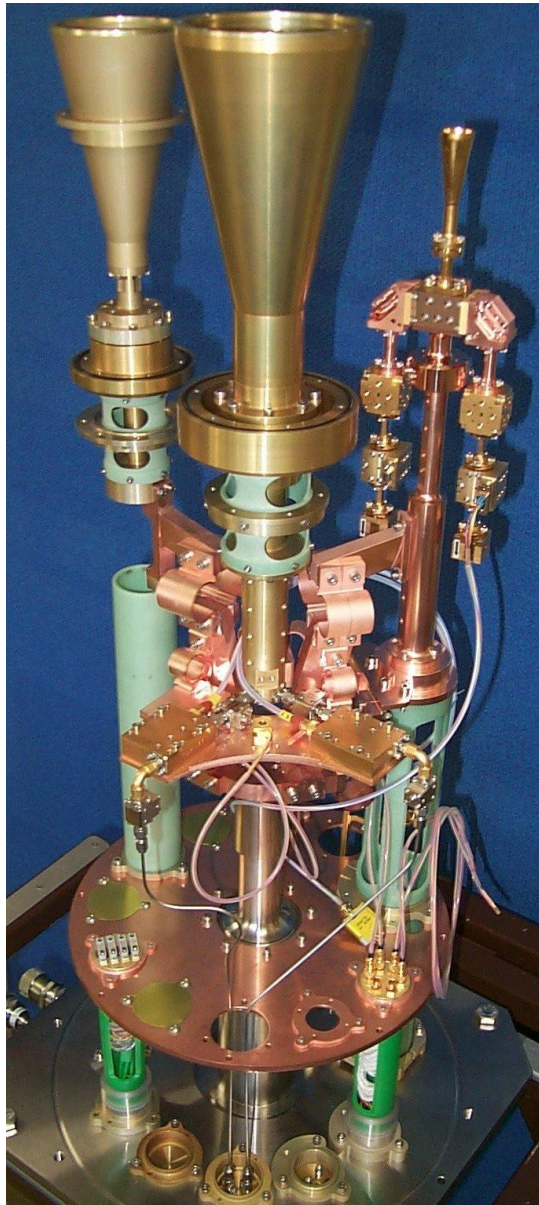

- New receivers for 16 to 25 GHz and 85 to 115 GHz bands.
- Extend LO generation for mm-wave converters.
- Upgrade LO reference distribution to single mode fibre optic cable

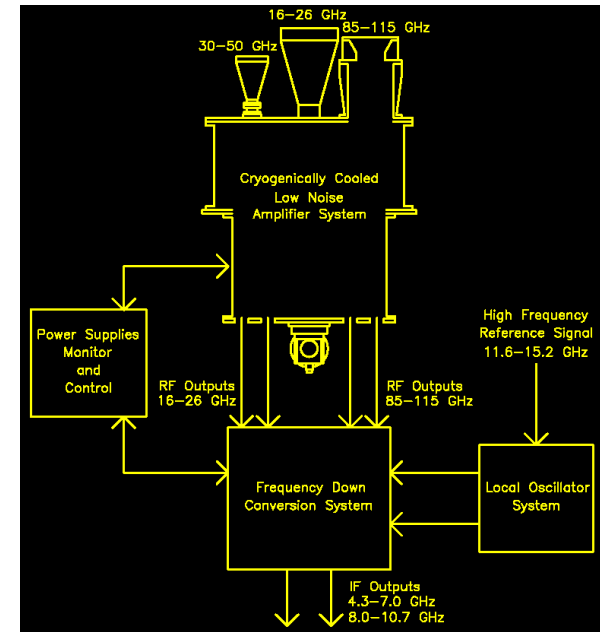

# mmwave MMIC Project

In 1997 a collaborative project was begun with CSIRO's CTIP Division to design and fabricate a range of mmwave MMIC devices using a 0.1 micron InP HEMT process developed by TRW.

These devices included LNA's, mixers, power amplifiers, frequency doublers, high speed samplers and individual chip HEMT transistors.

Funding for this project was made available from the CSIRO Executive's Special Projects Fund and the success of this design and fabrication process was a key factor in achieving the ultimate completion of the mmwave MNRF upgrade.

# Amplifier: 16 - 25 GHz

- **Amplifier design**

- three stages using 0.1 micron gate length, 120 micron wide, InP HEMTs
- individual control of each transistor bias
- source inductance feedback
- 3.1 mm x 2.25 mm

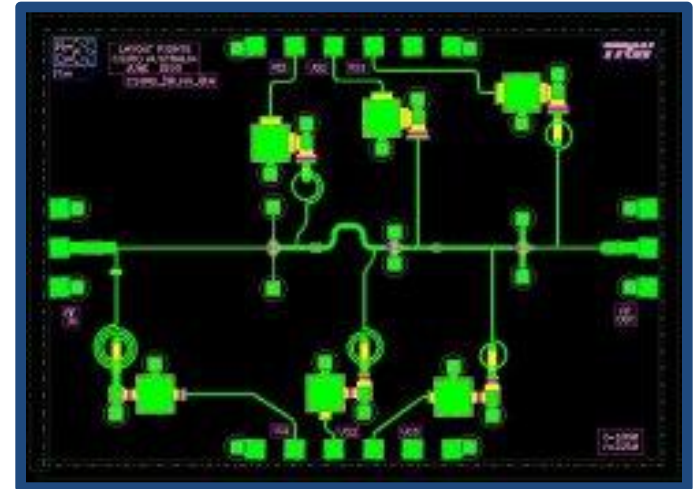

- **On wafer measured performance**

- 28.5 ±1 dB gain
- 1.7 dB noise minimum
- better than 10 dB return loss at input and output

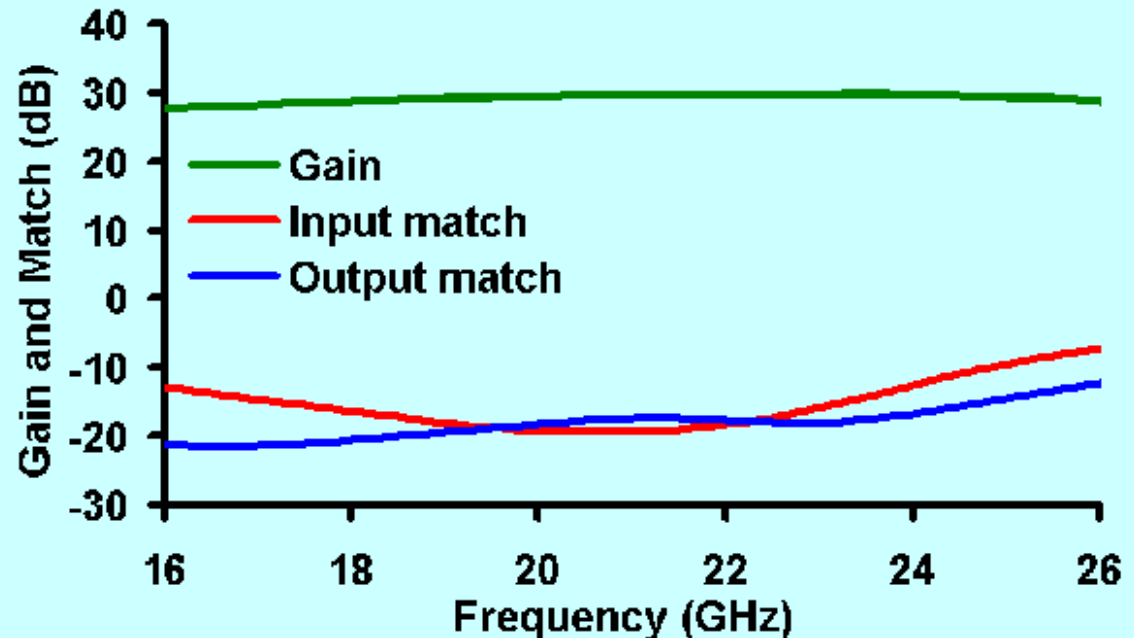

# Packaged Amplifier: 16 - 25 GHz

- **Mounted in Silvar body**  
To better match the thermal coefficient of expansion of InP
- **Cooled performance**  
~30 dB gain over 18-25 GHz band.  
< 20 Kelvin noise ( 0.3 dB noise figure )

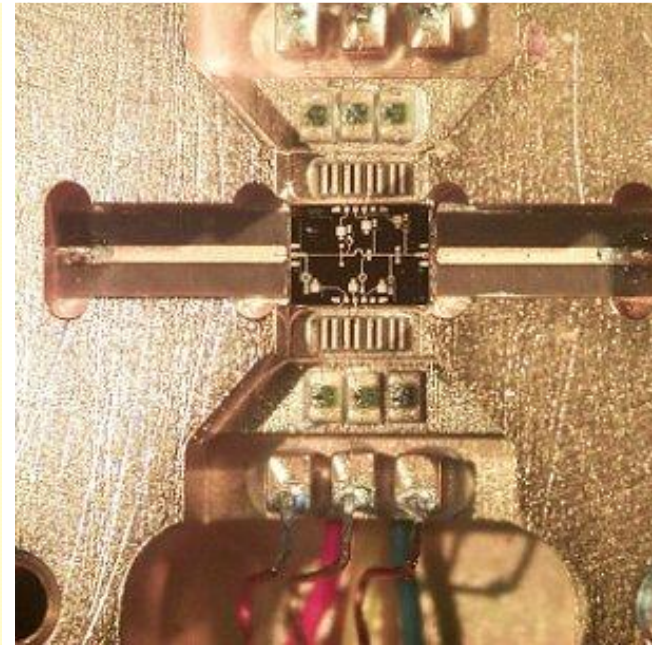
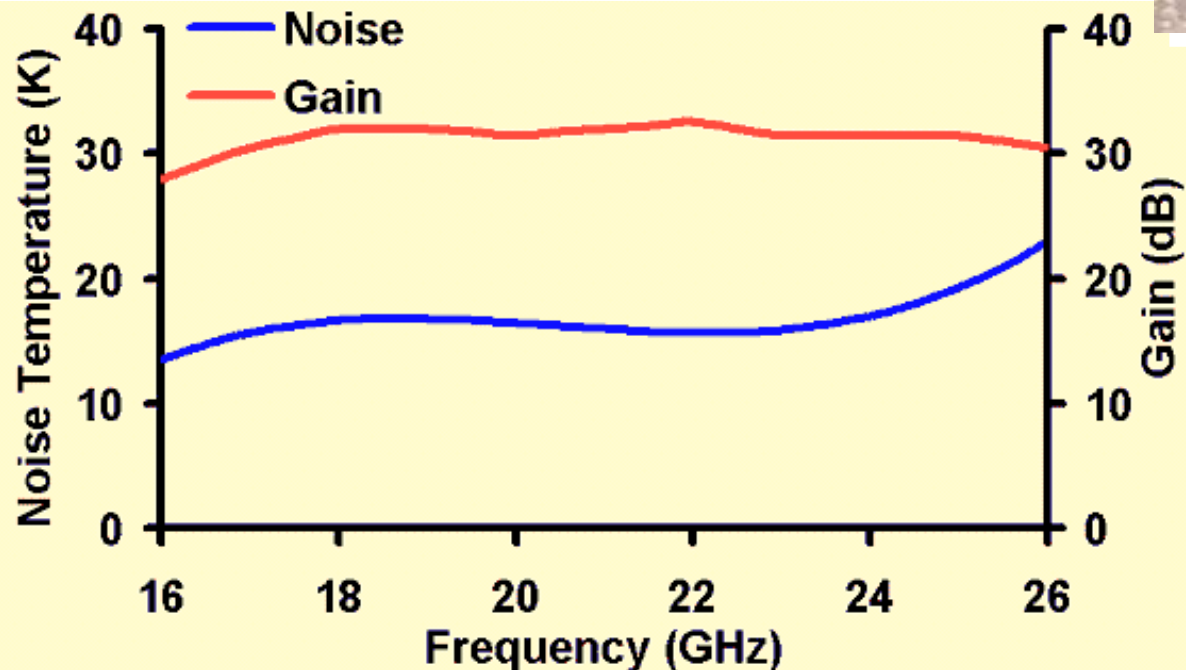
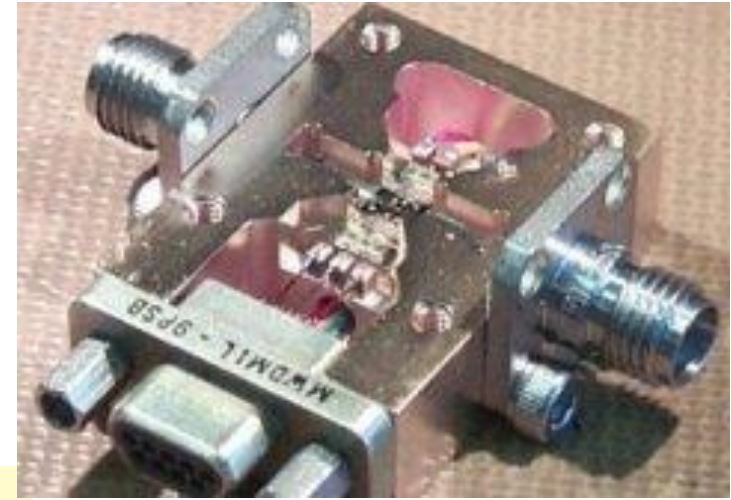

# Amplifier: 85 - 105 GHz

- **Amplifier design**

- four stages using 0.1 micron gate length, 40 micron wide, InP HEMTs
- individual control of each transistor bias
- source inductance feedback in each stage
- 2.1 mm x 2.25 mm

- **On-wafer measured performance**

- $16.5 \pm 2$  dB gain
- 4.0 dB noise minimum at 90 GHz
- better than 5 dB return loss at input and output in the 90 - 105 GHz band

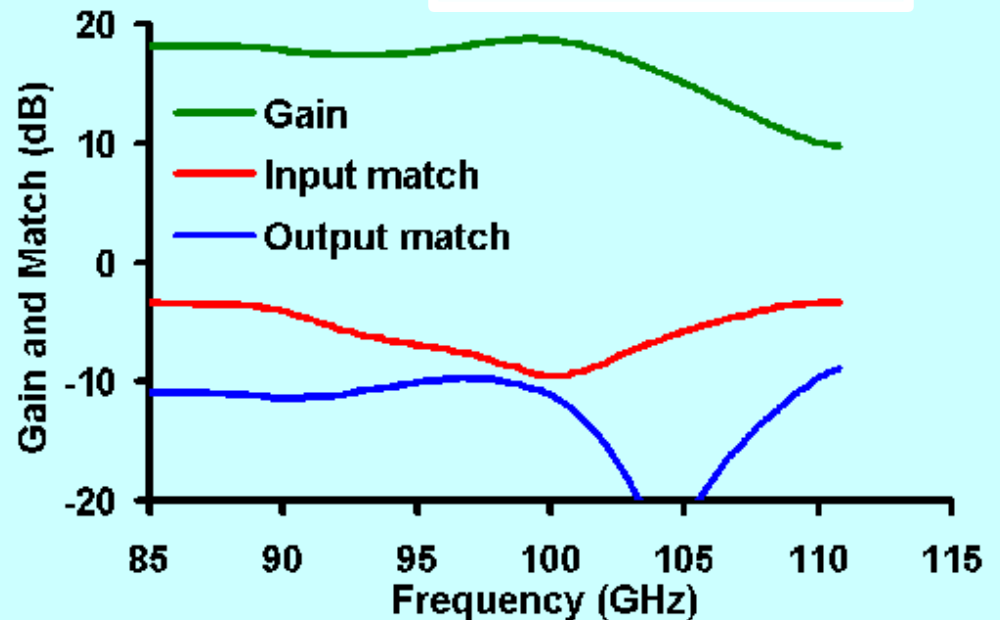
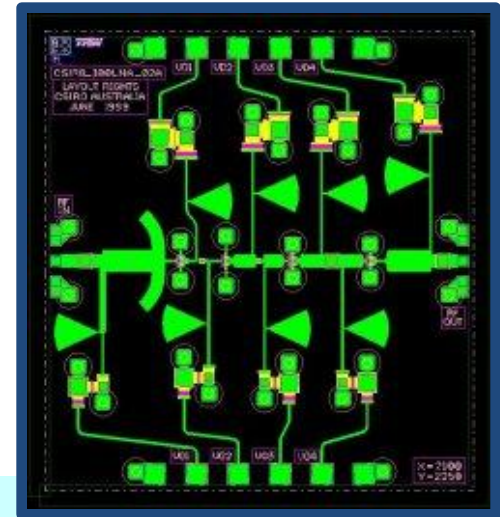

# Packaged Amplifier: 85-105 GHz

## Cooled performance

> 12 dB gain over the  
85-105 GHz band.

60 Kelvin noise minimum (0.1  
dB noise figure).

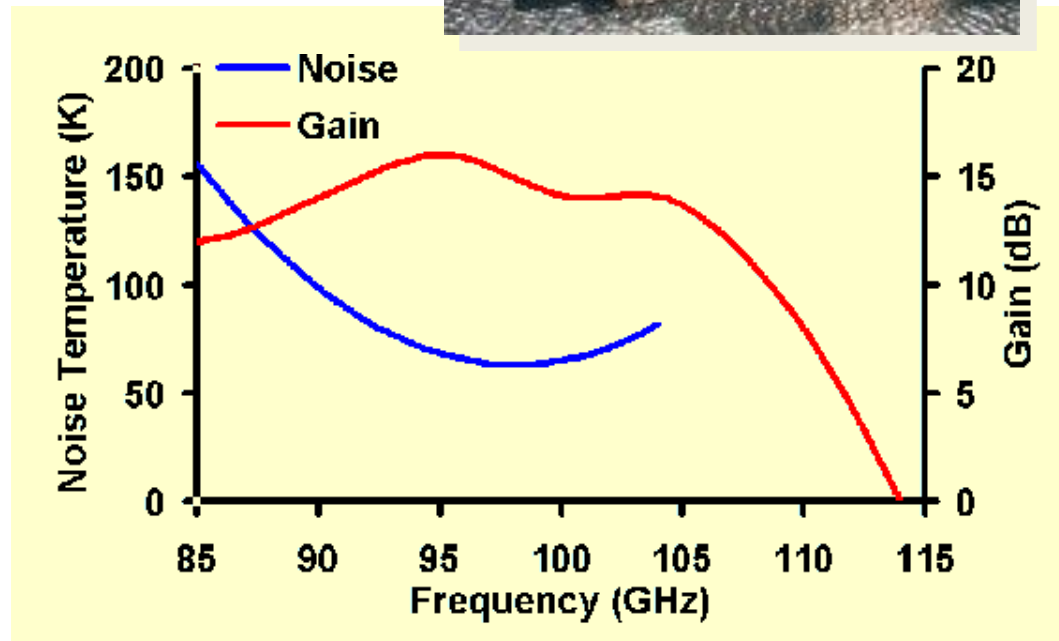
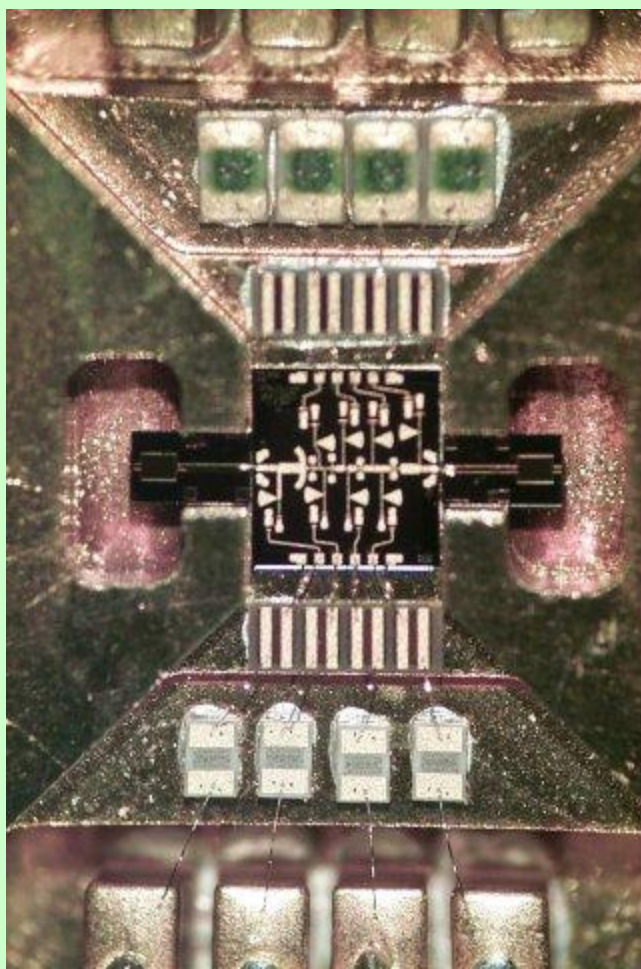

# mm-wave Receiver Performances

Frequency	System Temperature (Kelvin)	
	Receiver (Horn input)	On-sky (at zenith)
20 GHz	19	36
100 GHz	140	200

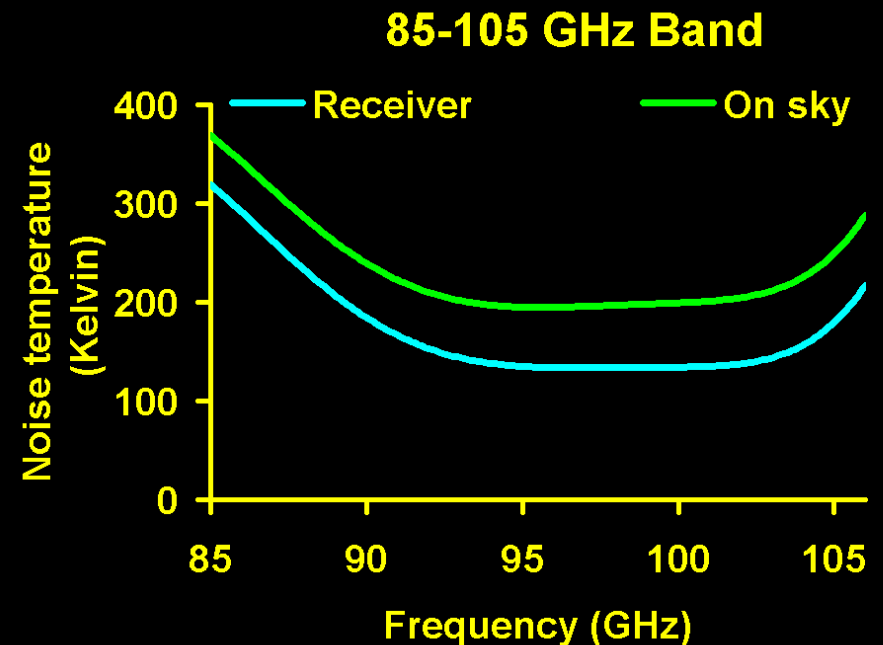
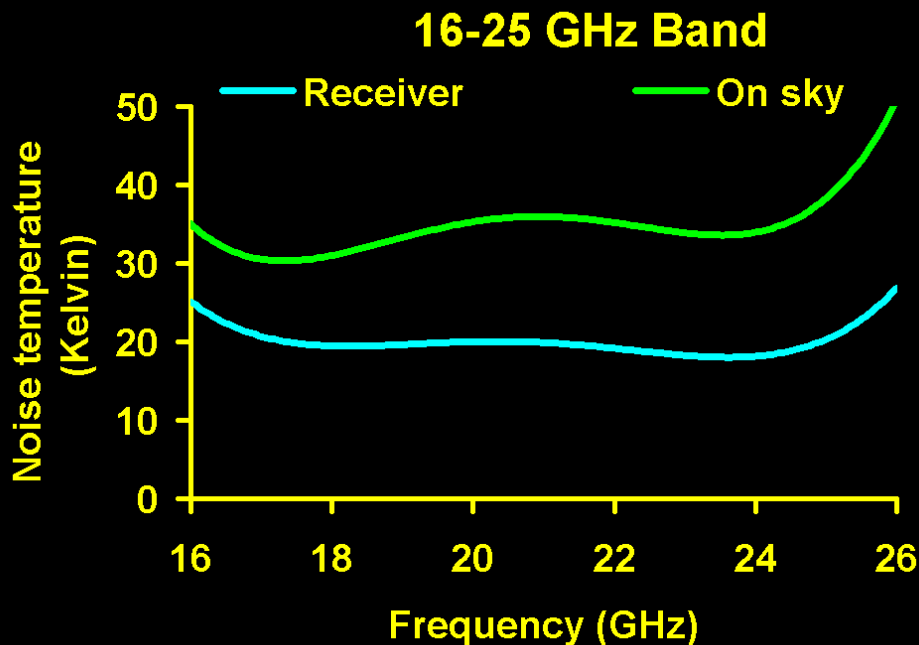



# Preliminary results....

*Courtesy of Tony Wong*

**Spectra of molecular  
cloud M17SW**

**Obtained using the  
85-105 GHz receiver**

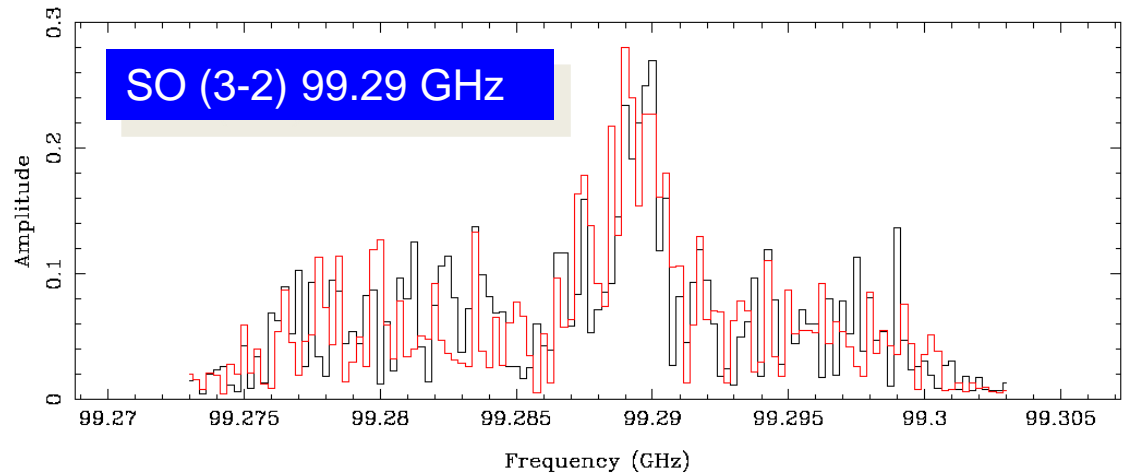
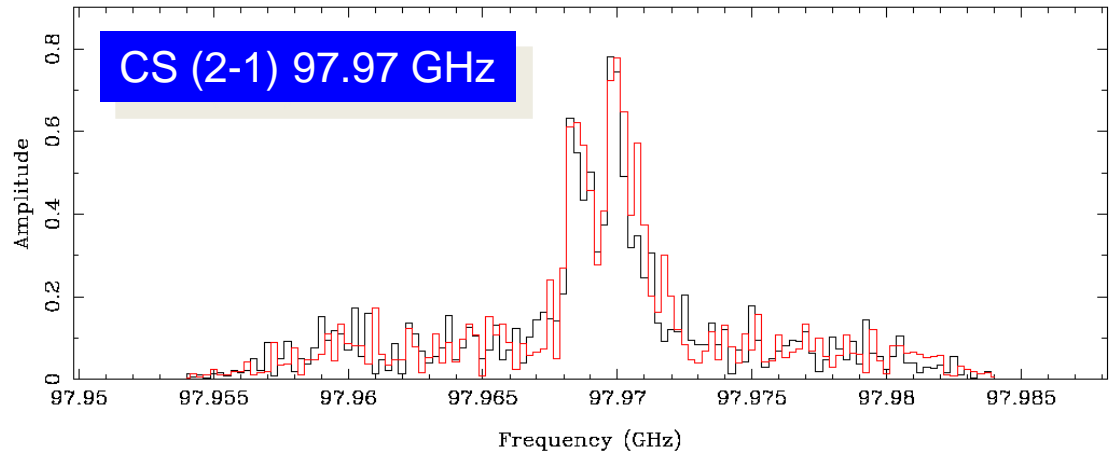

**Optical image of M17**  
photo by David Malin AAO

# COMPACT ARRAY 20/13 Cm and 6/3.4 Cm UPGRADE

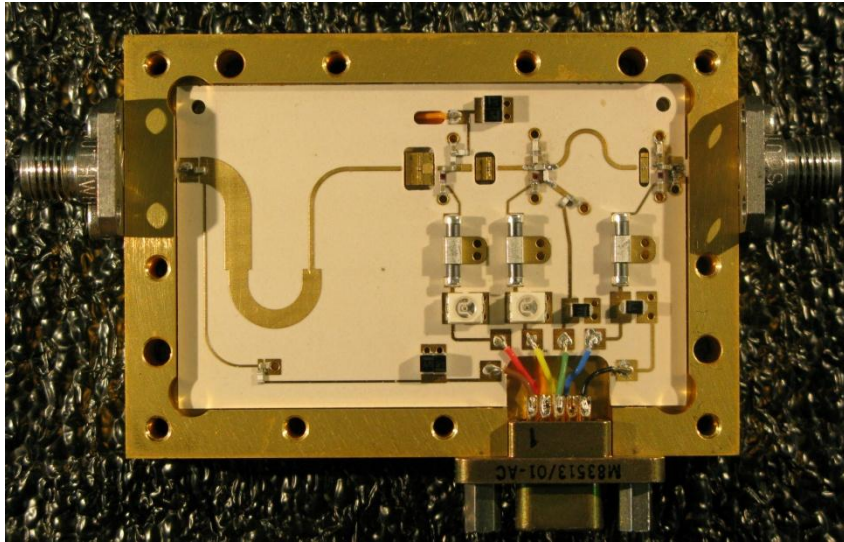

- This amplifier, using the TRW 0.1 micron InP HEMT chip transistors on an alumina substrate now covers 1.2 to 3.0 Ghz and yields a 2 Kelvin noise temperature when cooled to 20 Kelvin.

Similarly, this amplifier using the same devices, enables the 4.5 to 11 Ghz band to be covered with similar low noise performance.

This means that the lossy band splitters in the original 20/13 and 6/3.5 CA front ends are removed and  $T_{sys}$  lowered accordingly.

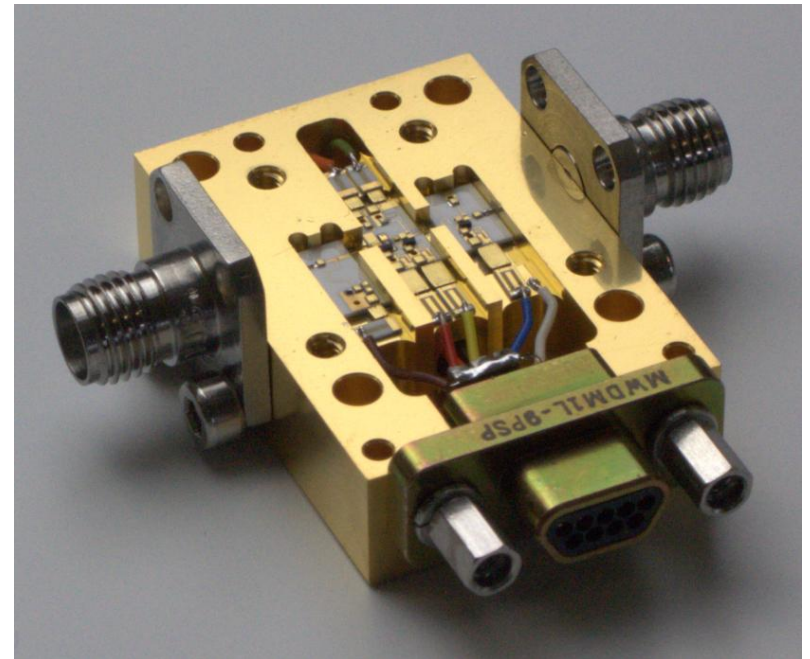

# ASKAP and the SKA - The future.

